

Ministry of Economic Development

DEPARTMENT FOR BUSINESS AND INTERNATIONALISATION
GENERAL HEAD OFFICE FOR MARKET, COMPETITION, CONSUMER, VIGILANCE AND TECHNICAL NORMS
XV Division – Measuring instruments and precious metals

TEST CERTIFICATE UCM 03/002 - B REVISION I

Issued by XV Division – Measuring Instruments
Via Antonio Bosio, 15 - 00161 ROMA (I)
Notified Body Nr. 0201

In accordance with Paragraph 8.1 of the Italian Norm UNI CEI EN 45501 ed.1998 concerning the metrological features of non-automatic weighing instruments. With reference to paragraph 3.5.4 of this standard, the applied p_i fraction error is 0.5 (see footnote).

Applicant DINI ARGEO s.r.l
Via della Fisica, 20 - 41042 Spezzano di Fiorano – (MO) (I)

In respect of Weight indicator device tested as part of a weighing instrument.
Manufacturer:
Dini Argeo s.r.l Via della Fisica, 20 41040 Spezzano di Fiorano Modena (I)
Type: “DFW”, “DF” or “DFWL”

Features Weight indicator device linkable to non-automatic weighing instruments with single or multiple weighing ranges, with the following characteristics:
Precision class: III o IIII
 $n \leq 10\,000$ for class III instruments
 $n \leq 1\,000$ for class IIII instruments

Description The main features are reported in the annex which is an integral part of this test certificate and consists of 19 pages.
The technical documentation is included in the pamphlets attached to file 015/09

Roma, August 5th, 2009

the Manager
(*Gabriella Di Bella*)

NOTE: This Test Certificate is not an approval certificate in accordance with the requirements of the 90/384/ EEC Directive. This Test Certificate is the exclusive property of the applicant company which may authorise its citation by other manufacturers in CE Type-approval Certificates.

The “ p_i ” fraction of error reported in the “in accordance with” paragraph must be considered as the maximum value for the application of the Test Certificate.

Via A. Bosio, 15 – 00161 Roma
The procedure manager: Renato Insola
e-mail renato.insola@sviluppoeconomico.gov.it
www.sviluppoeconomico.gov.it



ANNEX TO THE UCM 03/002-B TEST CERTIFICATE REVISION I

1 GENERAL INFORMATION

The instrument is an electronic weighing indicator module designed to convert the analog signal originating from strain-gauge load cells into digital data. The obtained data may be displayed, made available for weighing operations and transmitted to external peripheral units.

In respect to the DFW, the DF instrument is fitted with technically updated circuits.

The DFWL instrument is a version with a circuit simplification in respect to the DFW.

2. TECHNICAL DATA

Types of power supply:	with 6 V battery with 12 - 24 V DC 110 - 230 V AC through external or internal power supplier
Minimum battery voltage value	5,5 V (DFW) 4 V (DF and DFWL)
Cell power supply	Up to 5 V DC $\pm 5\%$
Minimum voltage value for each interval	0,3 μ V
Minimum impedance of the load cell	42 Ω (DFW) 20 Ω (DF and DFWL)
Maximum impedance of the load cell	10 k Ω
Operating temperature	From -10 to +40 °C
Pi Fraction of the maximum allowed error	0,5
Conversion speed	From 6 to 100 scans per second (DFW) Up to 1600 scans per second (DF and DFWL)
Sensitivity (analog signal input)	From 0,8 to 3,2 mV/V (DFW) from 0,6 to 5 mV/V (DF and DFWL)
Maximum input signal	16 mV (DFW) 30 mV (DF and DFWL)
“remote sensing” device	Present - selectable
Connection cable specifications	Shielded with 4 or 6 wires



ANNEX TO THE UCM 03/002-B TEST CERTIFICATE REVISION I

3 FEATURES

3.1 METROLOGICAL FEATURES

Adjustment and calibration device	Through contact jumper protected by seal
Initial zero-setting device	≤ 20 % of Max.
Zero-tracking device	Total effect
Semi-automatic zero-setting device	≤ 4 % of Max.
Semi-automatic tare device (subtractive):	T- = Max.

3.2 MAIN DEVICES

3.2.1 Power feeder

Stabilizes the continuous voltages necessary for the instrument's functioning.

The feeder is able to supply a stabilized voltage of up to 5 Vdc which allows to feed up to 8 load cells of 350 Ω each (or up to 16 of 700 Ω , or up to 24 of 1000 Ω) with the DFW, and up to 16 load cells of 350 Ω each (or up to 32 of 700 Ω , or up to 48 of 1000 Ω) with the DF and DFWL, and is protected by accidental short-circuits.

3.2.2 Analog/Digital converter

This device has the task of converting the signal coming from the load cell/s and convert it into a digital datum to be transmitted to the central processing unit.

The cells may be connected on up to 4 distinct channels, each of which is treated independently by the converter.

3.2.3 Display

The weight data and the functions' symbols are shown on LED, GAS, LCD graphic and/or alphanumeric displays. Any eventual accessories, recognizable in respect to the data resultant from the weigh, can be temporarily shown on the same display.

3.2.4 Keyboard

On the front panel of the DFW, DF, or DFWL series' instruments there is a keyboard which can have from 3 to 100 keys, each with various functions for managing the weight, for setting the general Set-Up and eventual ancillary data, and for activating additional functions.



ANNEX TO THE UCM 03/002-B TEST CERTIFICATE REVISION I

3.2.5 Processing unit

CPU card for managing the entire system made up essentially of:

- microprocessor inside which there is:
 - FLASH memory for the residing program;
 - RAM memory for storing the variable data;
- devices for controlling all the subsystems managed by the microprocessor
- interface devices

3.3 MAIN FUNCTIONS

The functioning of the equipment includes the:

- Cancelling function of the automatic or manual tare through the keyboard.
- Storage database for prefixed tare values recallable through the keyboard.
- Accumulation of weighs with possibility of clearing after the printout or the transmission.
- Piece COUNTING function with automatic calculation of the APW on the basis of a reference quantity entered from the keyboard.
- HOLD function; in other words, the weight is frozen, blinking on the display.
- PEAK function; the maximum weight value detected by the scale, is stored.
- Temporary extended indication function, commanded manually.
- Connection with up to 4 different load receivers through 4 independent channels of which the converter is fitted.
- Connection with up to 64 converters of the same type (DF and DFWL)
- Connection with up to 64 digital cells through the serial line (DF and DFWL)
- Activation and selection from keyboard for the:
 - display of the weight value of each single receiver
 - display of the sum of weight values of 2 or more receivers
 - accumulation, transmission and printing of displayed weight values
- Setting and management of ancillary data such as numeric codes, ticket heading, and predisposition of their eventual transmission.
- Automatic management of the progressive number of the weighs.
- Transmission of the weight data and the ancillary data towards peripheral units through serial line or analog input/output devices.
- Reception of ancillary data and functional commands on behalf of connected external devices.
- Functioning as remote weight repeater, connected to another instrument through the serial line or the radio frequency RF interface, or any foreseen interfaces, and of which it repeats indications or indications and functions.
- Semi-automatic dosage function of products or weight indication within tolerance through the activation of loading servo-mechanisms. In any case the exact weight of the desired quantity is obtained by the operator.
- Possibility of remoting the main commands with remote control by infrared ray or by radio.



ANNEX TO THE UCM 03/002-B TEST CERTIFICATE REVISION I

3.3.1 Device for storing and recalling the weight values transmitted to PC (alibi memory)

This is a memory unit inside the indicator and not accessible without removing the legal seals.

The information relative to each weigh made by the instrument is transmitted externally and stored in the Alibi Memory, only after it's been integrated with a code (or "ID") which identifies unambiguously the weigh. The external unit memorises and prints both data (weight and ID).

A procedure made with the indicator's keyboard, which may vary depending on the version, allows to view the information relative to the weigh corresponding to the requested ID; in this way it is possible to check the weighs reported in the documents made by external units.

The weight storage and the transmission of the ID are obtained only if the indicated weight value is stable and if the gross weight is not negative.

The minimum memory unit used allows to memorise a number of weighs equal to about 100,000 (one hundred thousand). Once arrived at 100,000 weighs the memory is rewritten from the beginning replacing the old data.

3.4 SOFTWARE

When the DFW indicator is turned on for the first time a 10-digit code will appear on the display indicating the type of instrument, the software version subject to legal restrictions and the software program version which does not involve variations with the essential requirements of the EN45501 norm.

The displayed abbreviation is made up of : *prefix/version/suffix*

The *prefix* shows the instrument model and may be made up of numeric or alphanumeric characters of variable length.

The *version* shows the legally constrained software version and is made up of two numeric characters.

The *suffix* shows the software program version and is made up of 6 numeric characters in the xx.yy.zz format

Model	EPROM version code
DFW, DF, DFWL	02.01 xx.yy.zz

Prefix 02 : indicates the model

Version 01 : indicates the legal software version

Suffix xx.yy.zz : indicates the freely modifiable software program version.



ANNEX TO THE UCM 03/002-B TEST CERTIFICATE REVISION I

3.4.1 Indication of the code

The code appears automatically and temporarily on the main display of the indicator each time it is turned on with the “ON” key before the scale predisposes itself normally at zero. Since the code is longer than the available digits, it is displayed in 2 parts. First of all the *prefix* and *version* are displayed, and after a few seconds these are substituted by a *suffix*.

3.5 CONTAINER

The following alternatives are available:

1. Type 1 metallic case (DFW)
2. Type 2 metallic case (DFW)
3. Type 3 metallic case (DFW)
4. Open Frame type metallic case (DFW)
5. Stainless steel case (DFW, DF, DFWL)
6. ABS case (DFW, DF, DFWL)
7. PM version ABS case (DFW, DF, DFWL)
8. DFWL version ABS case (DFW, DF, DFWL)
9. *Open frame* metallic case foreseen to be included in other containers (DFW, DF, DFWL)

3.6 PRINTING AND INTERFACE DEVICES AND ADDITIONAL DEVICES

3.6.1 Print device (optional)

- connected to the indicator through interface

3.6.2 Interfaces (optional)

All the interfaces, where present, which allow the connection to external devices conform with what decreed by the UNI CEI EN 45501 norm, point 5.3.6.1.

- bidirectional serial line, for the transmission and data reception through the cable, or for connection to:
 - radio-frequency interface for the data transmission to an RF receiving peripheral unit;
 - Ethernet network interface, field Bus, USB, or Bluetooth;
- fiber optic serial line for the data transmission to printer, to remote weight repeater, or to remote computer;
- IR infrared ray reception device. Through a remote control it is possible to use the main function keys;
- Photomosfet outputs and optoisolated digital inputs for connection to electro-mechanical service equipment (alarms, control lights, consents and varied automation);
- Interface for analogue 0-10V input or output configurable as 0-20mA or 4-20mA, on optional card, for connection to PLC or to external sensors;



ANNEX TO THE UCM 03/002-B TEST CERTIFICATE REVISION I

- Interface for storage device and weight recall (alibi memory);
- Real time clock interface;
- Interface for MultiMediaCard extractable memory support;
- Interface card for electromechanical (“tilt”) or electronic type of inclinometer;
- Interface for temperature sensor;
- Distribution card of the signal coming from the cells of various (up to 4) connectable load receivers.
- Zener Barriers for the connection of instruments and/or load receivers in ATEX zone with instruments in safe zone.
- Module for converting the analog signal coming from the cells into a digital signal.

3.6.3 Additional devices

3.6.3.1 For applications in which verification is compulsory

It is admissible to use print devices and peripheral units already applied to scales provided with the CE type certificate, or supplied with suitable test certificates issued by notified bodies, according to the Legislative Decree of December 29, 1992, nr. 517, as long as these are technically and metrologically compatible.

3.6.3.2 For applications without verification obligation

Various additional devices may be connected such as card readers, bar code readers, modems, personal computers, PLC, printers of all types, electro-mechanic equipment for automation, etc..

3.7 Calibration

The calibration of the instrument from keyboard is made after having activated a specific jumper placed inside the processing module protected by seals. The initial adjustment data is stored in a non-volatile manner in the FLASH memory; it's protected by an automatic check (checksum) which allows to ascertain the integrity; in case of error the instrument's functioning is blocked. In case of terminals with repeater function the calibration function is not present.

4 DOCUMENTATION

The documentation presented for the issuing of the test certificate is registered at this Division and is recorded with the following reference:

File Nr. 015/09

5 SEALS

The protection seals can be applied in one of the following ways:

- by using self-adhesives which destroy themselves when detached;
- with the help of light alloys and percussion or pincer punch.

The application spots of the seals are shown in the drawings that are an integral part of this annex.



ANNEX TO THE UCM 03/002-B TEST CERTIFICATE REVISION I

6 INSCRIPTIONS

The identifying plate, made in self-adhesive material which destroys itself when detached, must show the following:

- Manufacturer's name or trademark
- Model name
- Precision class
- Serial number
- Number of this certificate
- Power supply
- Operating temperature

7 TESTS

7.1 Tests carried out for the release of the original test certificate for the DFW instrument

The following tests have been carried out on the DFW indicator device with a positive result as foreseen by the UNI CEI EN 45501 ed. 1998 norm and the WELMEC 2.1 document.

Temperature effect on the no load indication	CIBE Laboratory
Voltage variation	CIBE Laboratory
Short time power reductions	CIBE Laboratory
Electrical bursts	CIBE Laboratory
Electrostatic discharges	CIBE Laboratory
Immunity to radiated electromagnetic fields	G.S.D. Laboratory
Weighing tests (20°C, 40°C, -10°C, 5°C, 20°C)	CIBE Laboratory
Damp heat	CIBE Laboratory
Span stability	CIBE Laboratory
Repeatability	CIBE Laboratory
Stability of equilibrium	CIBE Laboratory
Tares	CIBE Laboratory
Warm-up time	CIBE Laboratory

7.2 Tests carried out for the release of this revision

The following tests have been carried out on the DF and DFWL indicator devices with a positive result as foreseen by the UNI CEI EN 45501 ed. 1998 norm and the WELMEC 2.1 document.

Weighing test (20°C)	CIBE Laboratory
Tares	CIBE Laboratory
Short time power reductions	CIBE Laboratory
Surge	CIBE Laboratory
Electrical bursts	CIBE Laboratory
Electrostatic discharges	CIBE Laboratory
Immunity to radiated electromagnetic fields	POLAB Laboratory



ANNEX TO THE UCM 03/002-B TEST CERTIFICATE REVISION I

"DFW" SERIES WEIGHT INDICATORS
TYPE 1 CASE VERSION

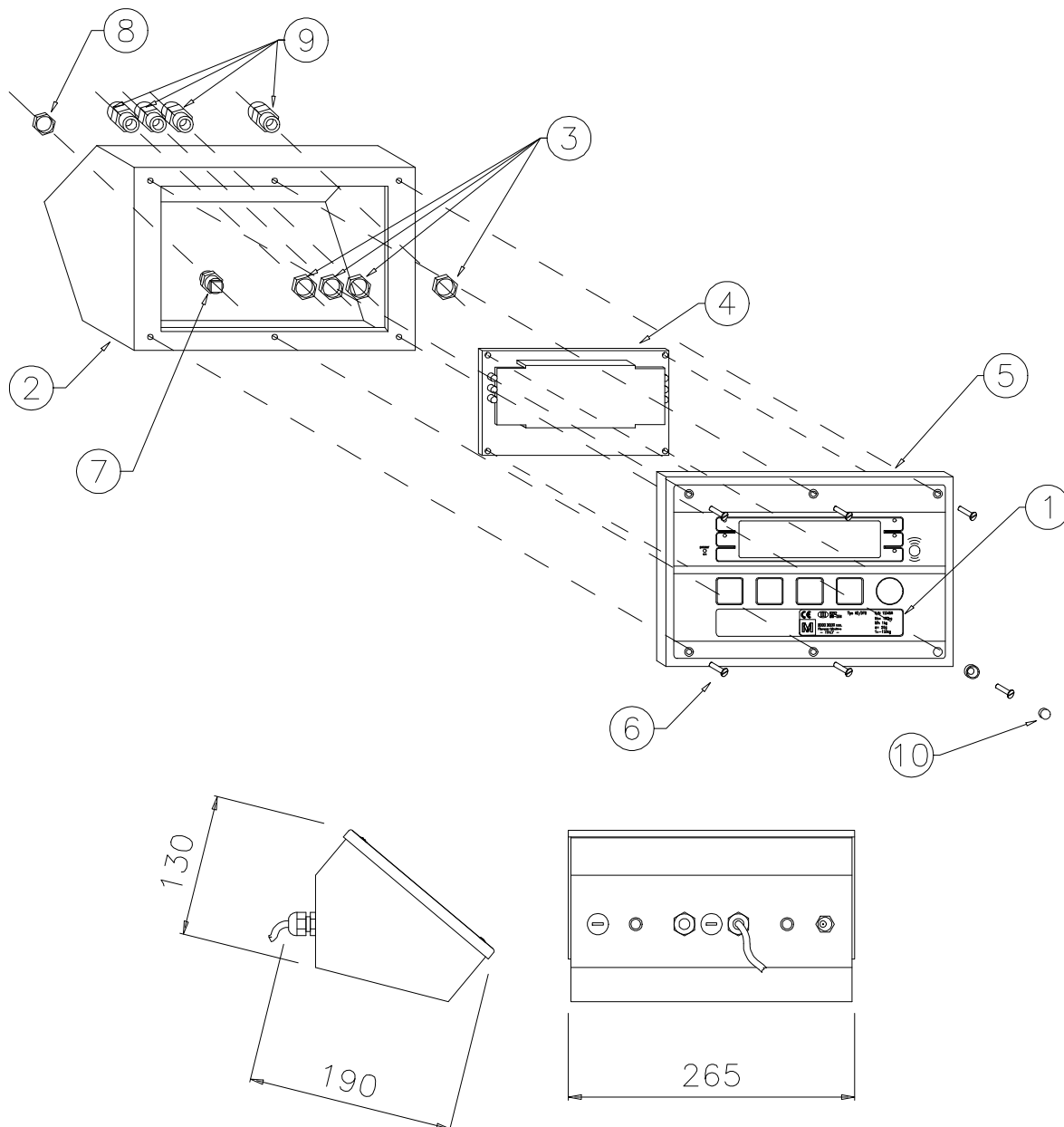

1. LEGAL SEAL
2. CASE
3. FAIRLEAD RING NUTS
4. ELECTRONIC CARD
5. FRONT PANEL
6. FRONT PANEL FIXING SCREWS
7. POWER SUPPLY CONNECTOR
8. POWER SUPPLY CONNECTOR FIXING RING NUTS
9. FAIRLEADS OR CONNECTORS
10. PROTECTION SEAL

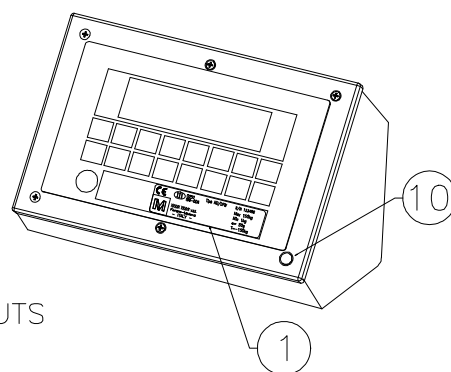



**ANNEX TO THE UCM 03/002-B TEST CERTIFICATE
REVISION I**

**"DFW" SERIES WEIGHT INDICATORS
TYPE 2 CASE VERSION**

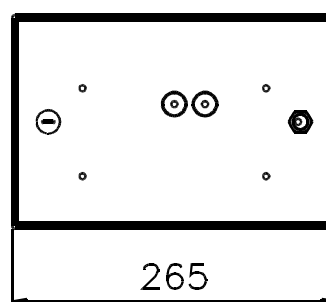
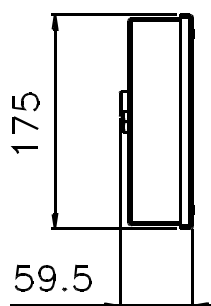
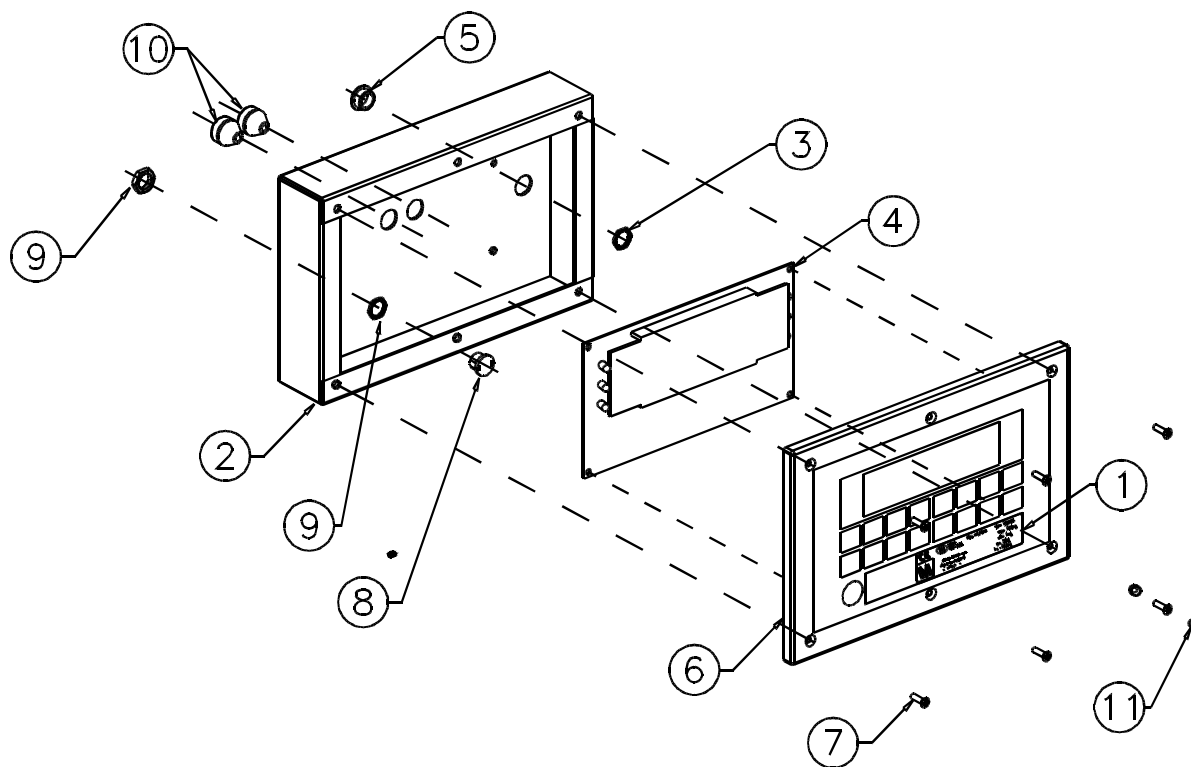

1. LEGAL SEAL
2. CASE
3. CAP RING NUT
4. ELECTRONIC CARD
5. CAP
6. FRONT PANEL
7. FRONT PANEL FIXING SCREWS
8. POWER SUPPLY CONNECTOR
9. POWER SUPPLY CONNECTOR FIXING RING NUTS
10. FAIRLEADS OR CONNECTORS
11. PROTECTION SEAL

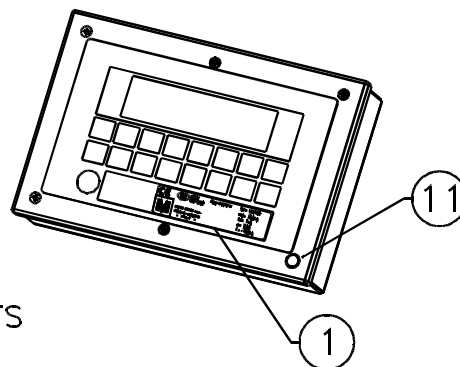



**ANNEX TO THE UCM 03/002-B TEST CERTIFICATE
REVISION I**

**"DFW" SERIES WEIGHT INDICATORS
TYPE 3 CASE VERSION**

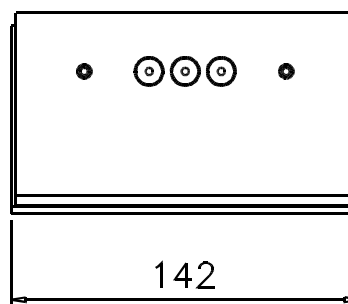
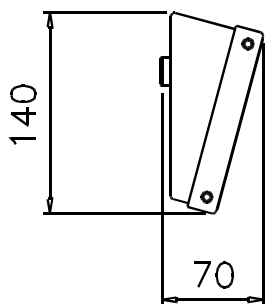
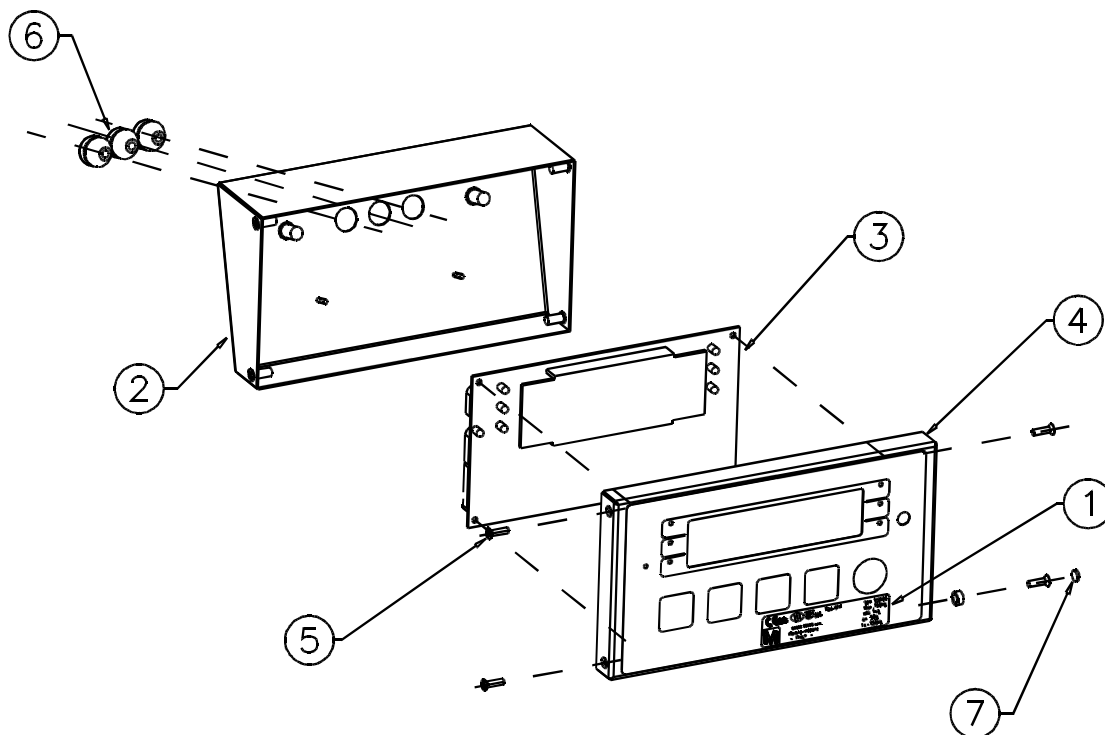

1. LEGAL SEAL
2. CASE
3. ELECTRONIC CARD
4. FRONT PANEL
5. FRONT PANEL FIXING SCREWS
6. FAIRLEADS OR CONNECTORS
7. PROTECTION SEAL

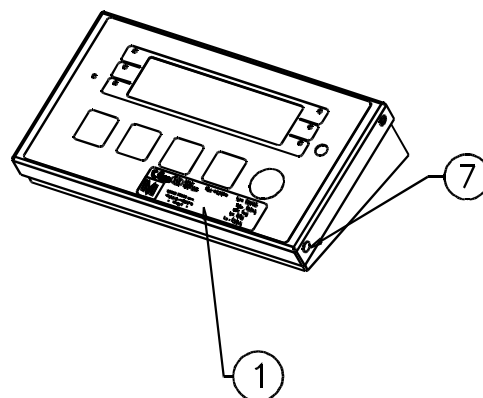



ANNEX TO THE UCM 03/002-B TEST CERTIFICATE REVISION I

"DFW" SERIES WEIGHT INDICATORS
"OPEN FRAME" VERSION FOR INSTALLING ON PANEL OF ANOTHER CASE

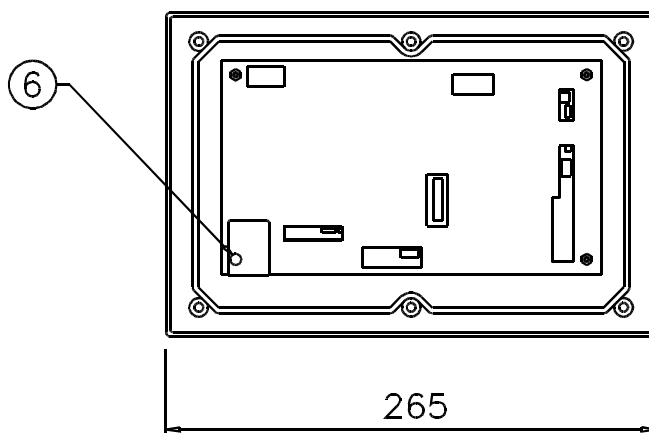
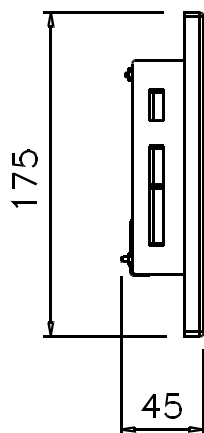
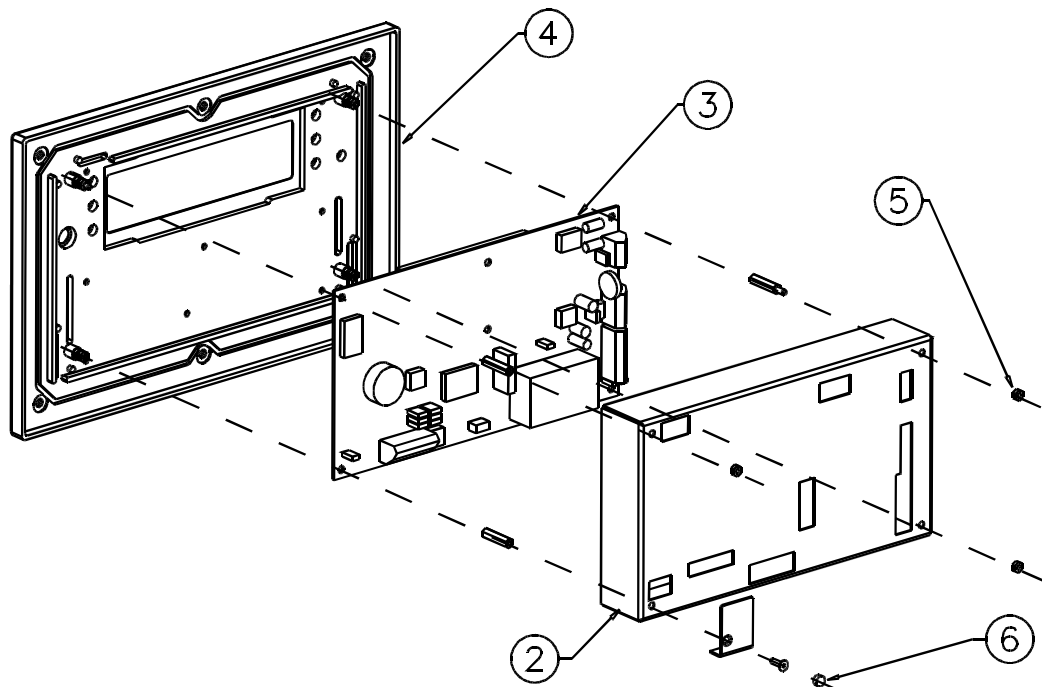

1. LEGAL SEAL
2. CASE
3. ELECTRONIC CARD
4. FRONT PANEL
5. CASE FIXING NUTS
6. PROTECTION SEAL

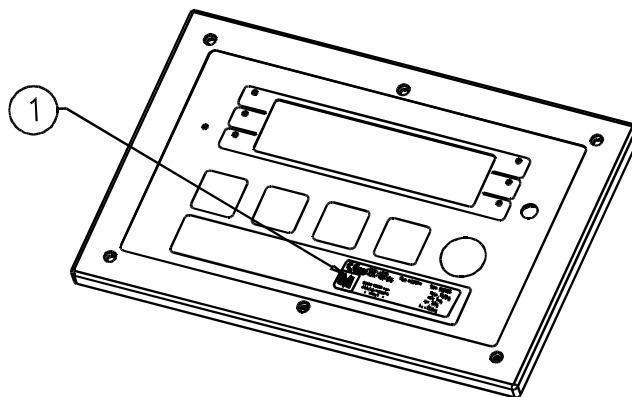



ANNEX TO THE UCM 03/002-B TEST CERTIFICATE REVISION I

"DFW, DF, DFWL" SERIES WEIGHT INDICATORS

ABS CASE VERSION

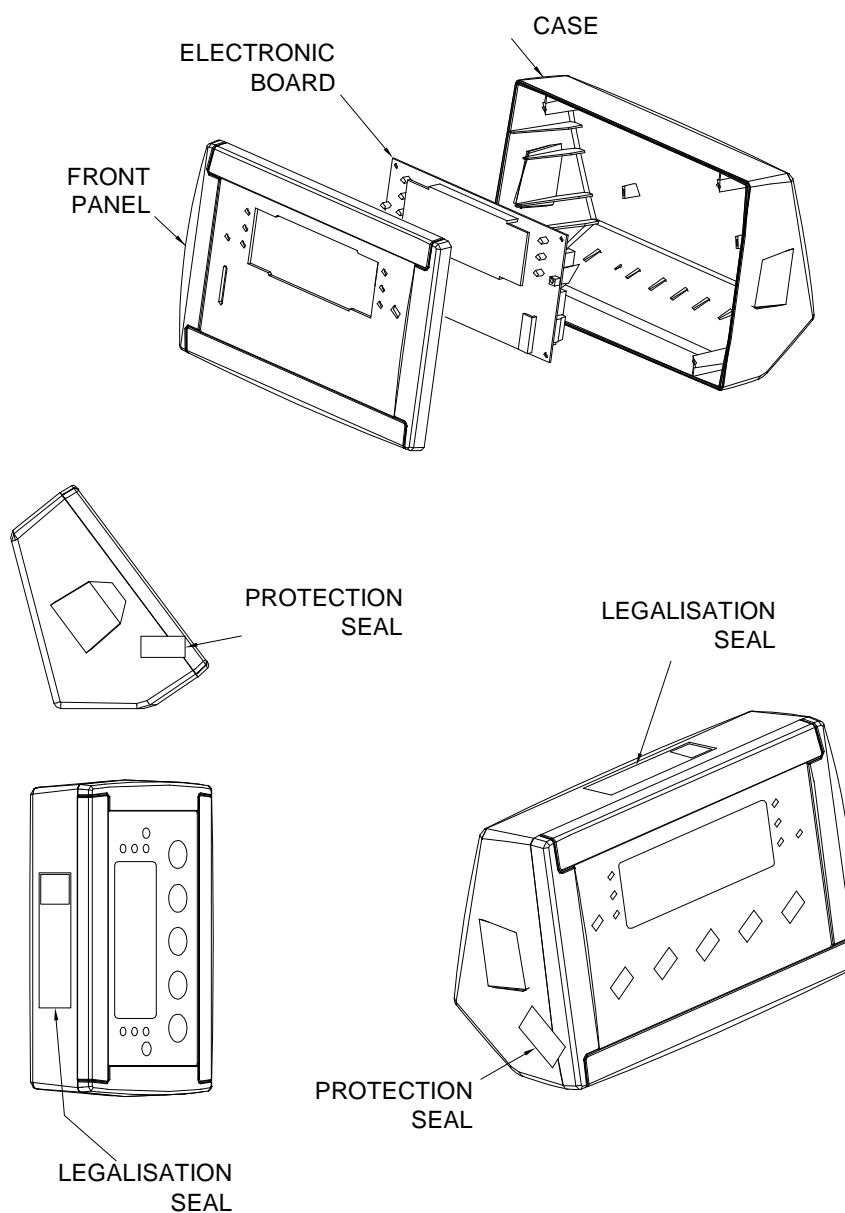



**ANNEX TO THE UCM 03/002-B TEST CERTIFICATE
REVISION I**

**"DFW, DF, DFWL" SERIES WEIGHT INDICATOR
STAINLESS STEEL CASE VERSION**

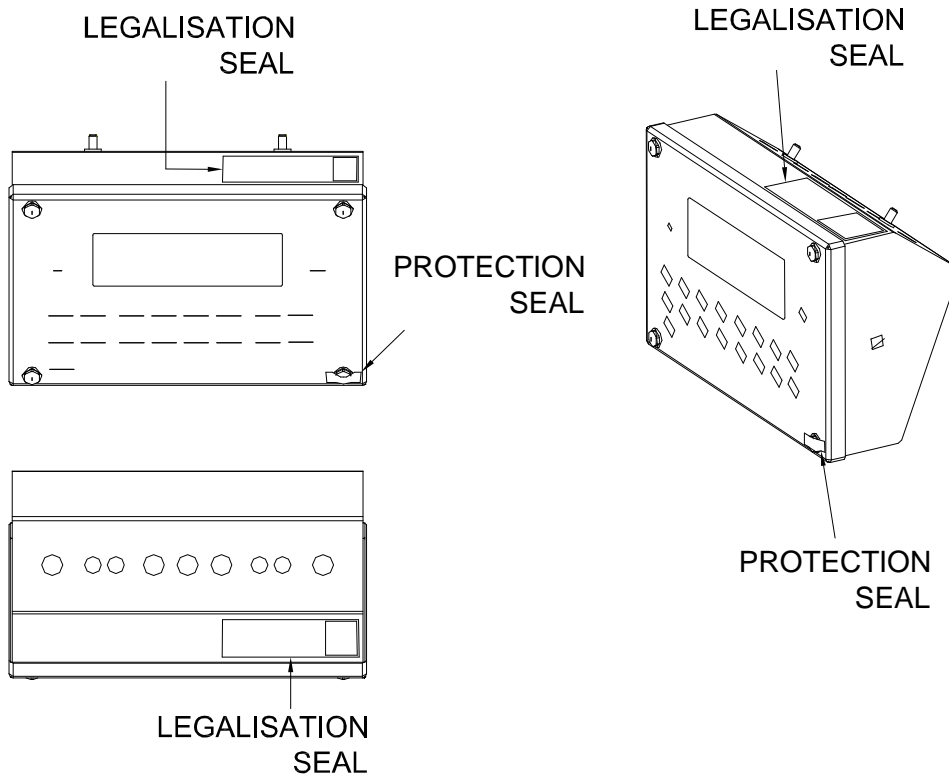
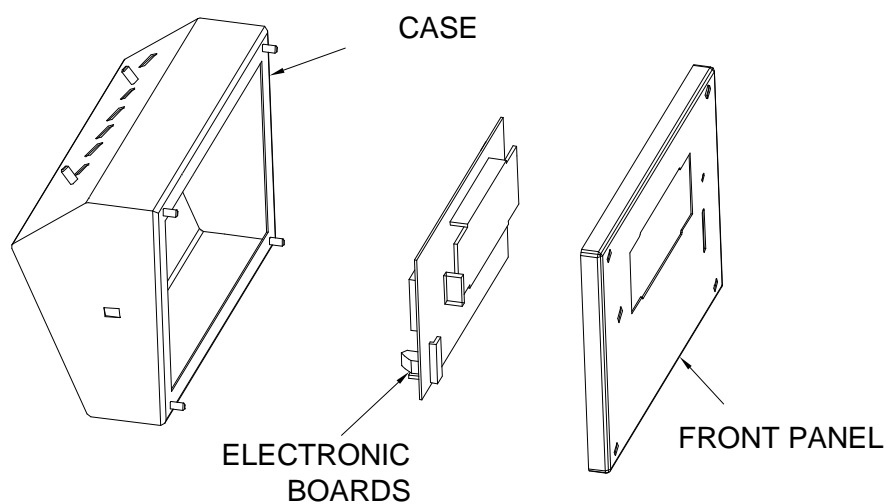



**ANNEX TO THE UCM 03/002-B TEST CERTIFICATE
REVISION I**

**"DFWL" SERIES WEIGHT INDICATOR
VERSION IN ABS CASE**

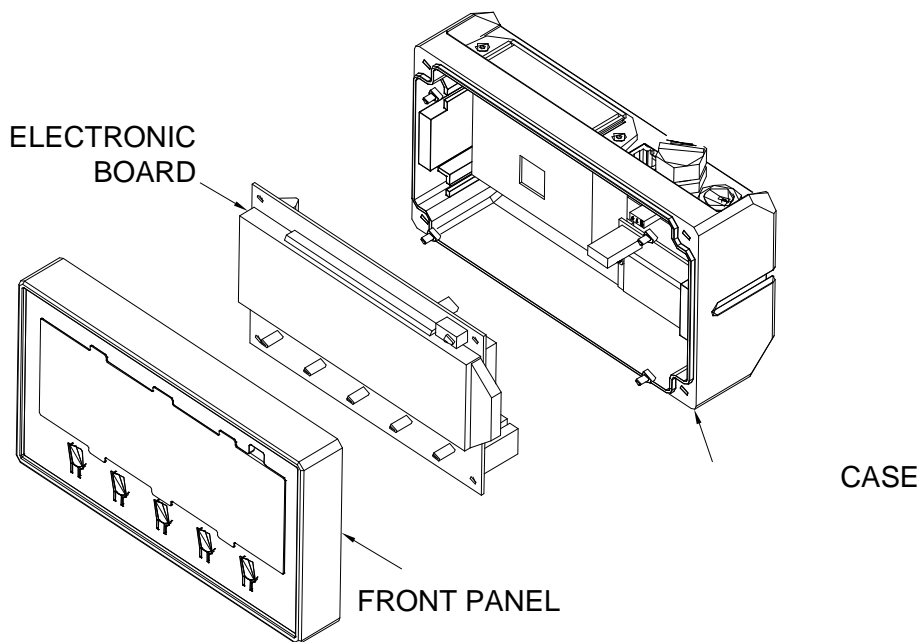

LEGALISATION
SEAL

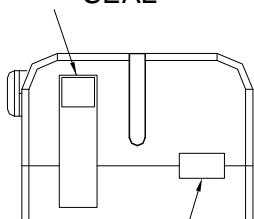

PROTECTION
SEAL

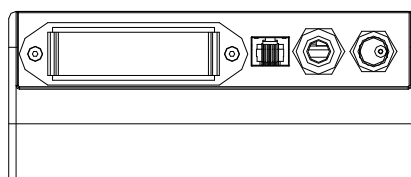

LEGALISATION
SEAL

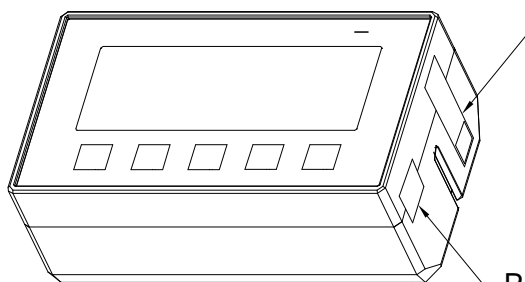

PROTECTION
SEAL



**ANNEX TO THE UCM 03/002-B TEST CERTIFICATE
REVISION I**

**"DFWL" SERIES WEIGHT INDICATOR
VERSION IN STAINLESS STEEL CASE**

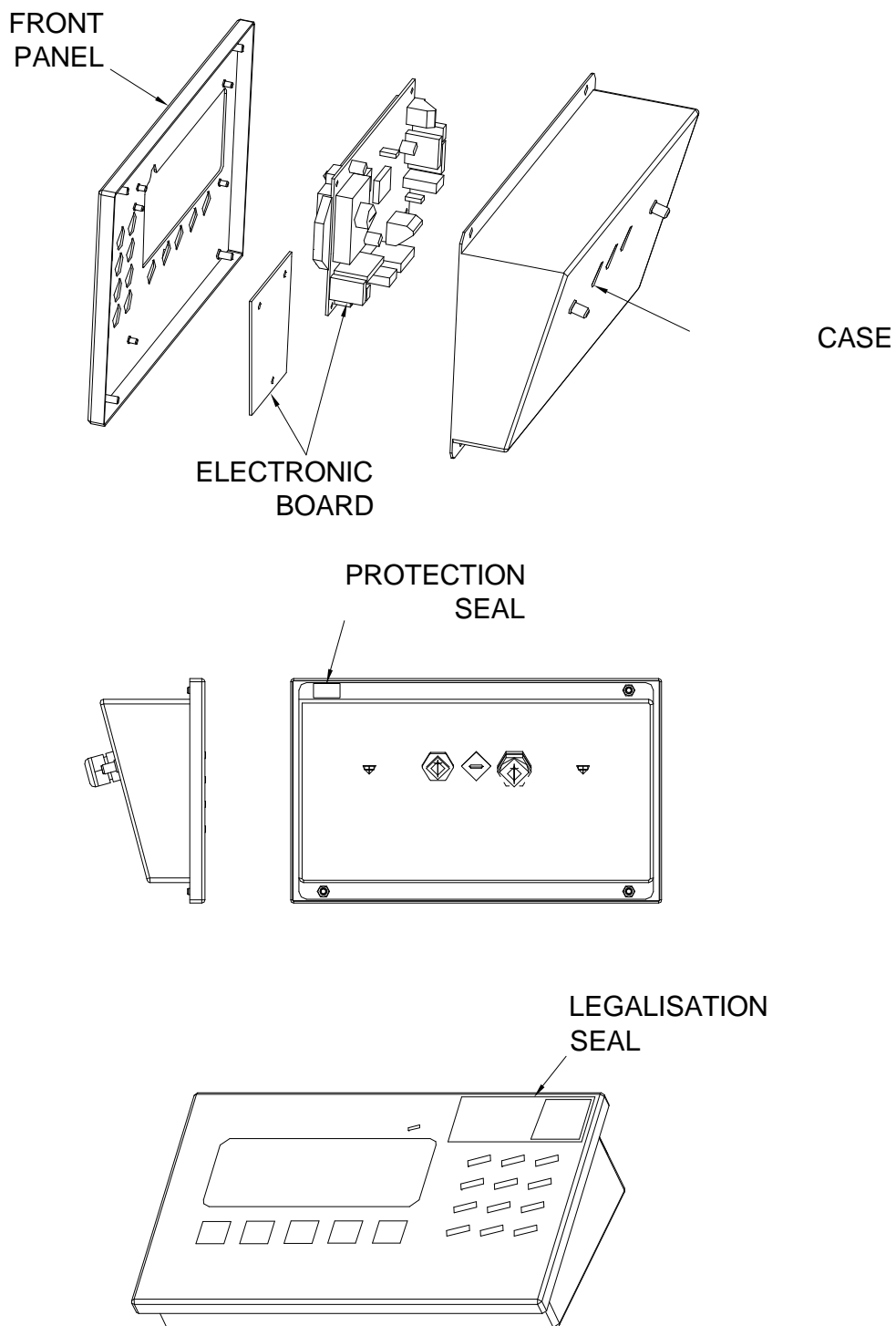



**ANNEX TO THE UCM 03/002-B TEST CERTIFICATE
REVISION I**

**"DFWL" SERIES WEIGHT INDICATOR
"PM" VERSION**

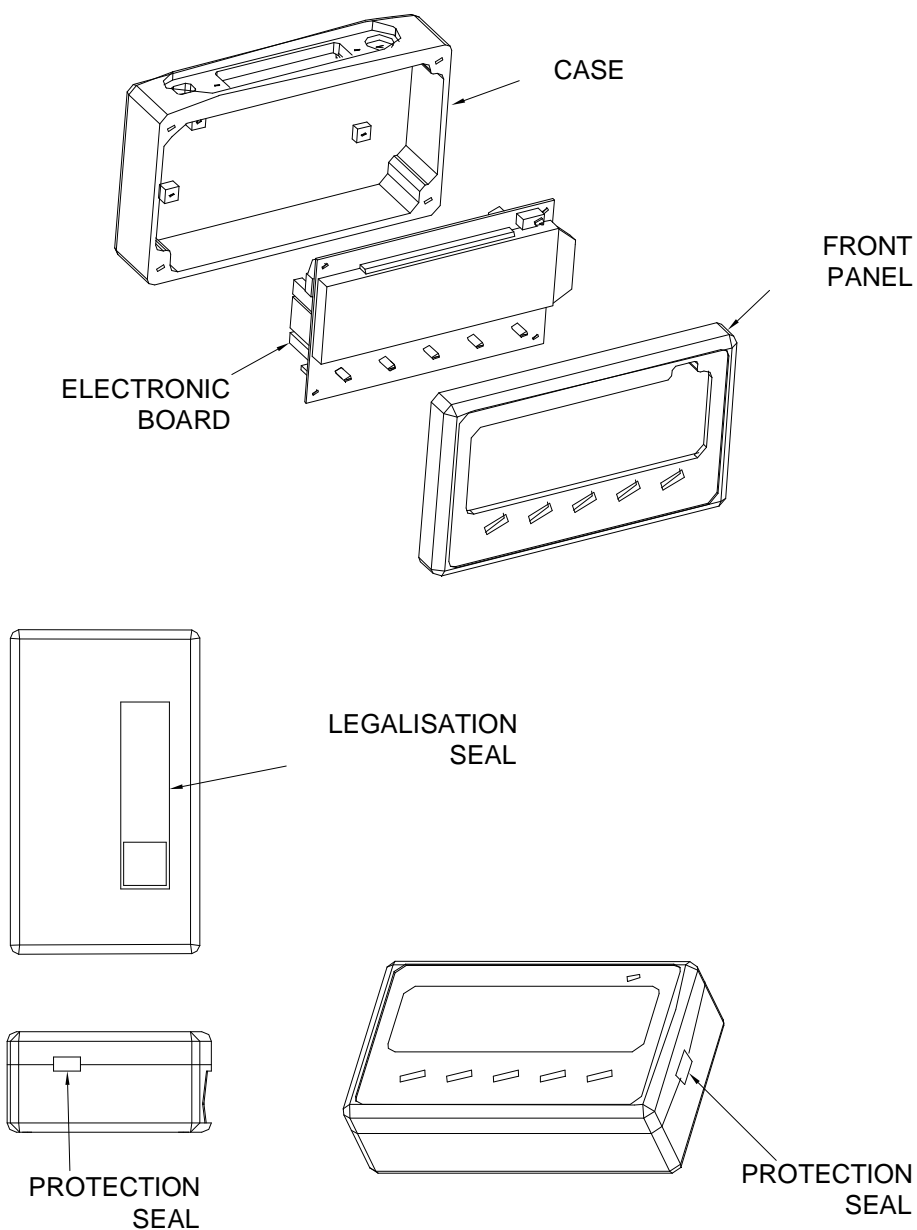



**ANNEX TO THE UCM 03/002-B TEST CERTIFICATE
REVISION I**

**"DFW, DF, DFWL" SERIES WEIGHT INDICATOR
"OPEN FRAME" VERSION**

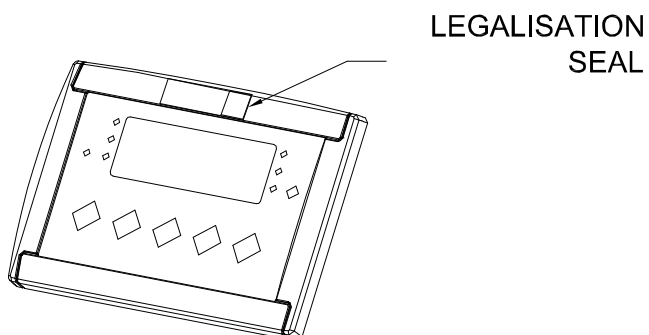
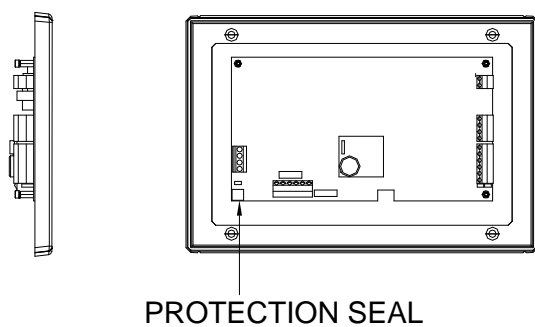
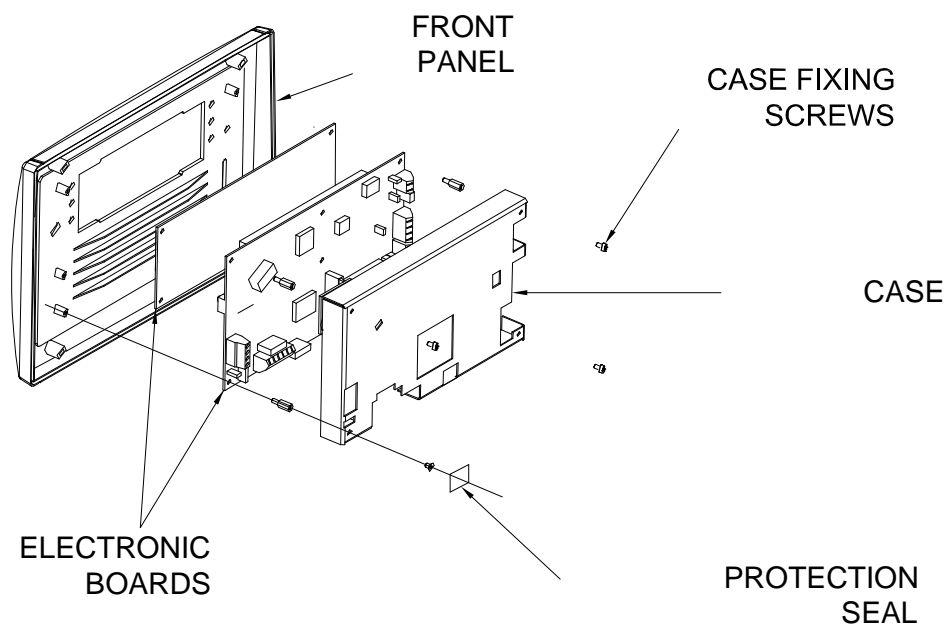



**ANNEX TO THE UCM 03/002-B TEST CERTIFICATE
REVISION I**

**"DFW, DF, DFWL" SERIES WEIGHT INDICATORS
"MINI OPEN FRAME" VERSION**

